

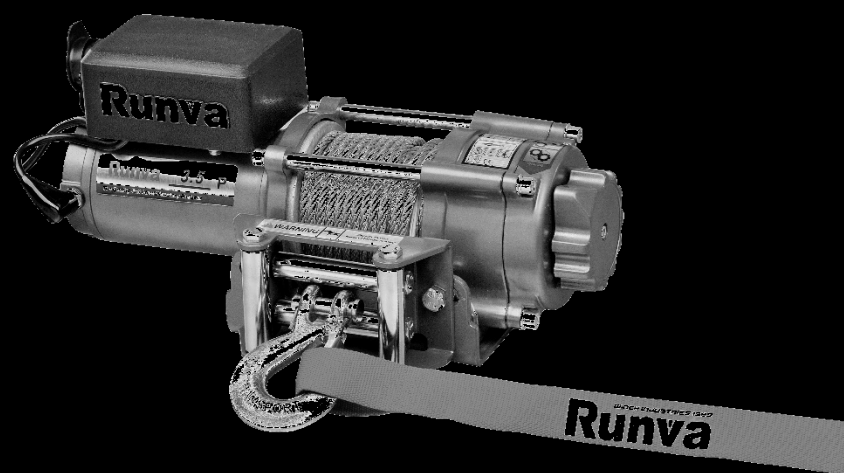

USER MANUAL

ELECTRIC WINCH
EP3500 / EP4500



CONTENTS

01. INTRODUCTION	2
02. GENERAL SAFETY INFORMATION	3
03. WARRANTY	4
04. RECEIPT OF EQUIPMENT	4
05. USAGE RESTRICTIONS.....	5
06. EQUIPMENT INFORMATION.....	6
07. MOUNTING - INSTALLATION	8
08. COMMISSIONING - USAGE.....	10
09. MAINTENANCE	13
10. DECOMMISSIONING.....	14
11. SPARE PARTS	14
12. TROUBLESHOOTING.....	15
13. EC DECLARATION OF CONFORMITY	16
14. EXPLODED-VIEW DRAWINGS	17

01

INTRODUCTION

Dear customer,

Thank you for choosing this high-quality winch, which has been designed and manufactured to strict specifications.

This manual has been carefully produced to provide you with all the necessary information for optimal installation and use of your equipment.

We recommend that you read it carefully before use and keep it close to hand for future reference.

We also reserve the right to make changes, without notice, as part of our continuous improvement of this product.

Please, do not hesitate to contact your RUNVA distributor if you wish to obtain more information:



4, rue Michel Hammid
 60420 FERRIERES (France)
 ✉: contact@huchez.fr
 ☎: 03 44 51 11 33

⚠ WARNING

**Please read, study and follow all instructions before using this equipment.
 Failure to follow these instructions could result in serious injury
 and/or damaged equipment.**

02

GENERAL SAFETY INFORMATION

All users should read the usage instructions carefully before first use. These instructions should enable the user to familiarise themselves with the winch and achieve the best performance possible. The usage instructions contain important information about how to use the winch correctly and safely. By acting in accordance with these instructions, you will avoid hazards, reduce repair costs, reduce downtime and increase reliability and extend the life of the winch. The instruction manual should always be available at the winch's point of use. In addition to the usage instructions and the relevant regulations for the prevention of accidents, it is also important to consider the applicable health and safety regulations in force in each country.

The winch can produce significant pulling forces. If it is used in an unsafe or inappropriate way, it could result in damaged equipment, serious injury or death. Throughout this manual, you will find the following symbols, indicating cautions, warnings and hazards. Pay particular attention to the notes accompanying these symbols because they are written for your own safety. As the operator, you are responsible for using this device safely.

**CAUTION**

This indicates a potentially hazardous situation which, if not avoided, could result in minor or moderate injury. This symbol is also used to warn you against unsafe practices.

**WARNING**

This indicates a potentially hazardous situation which, if not avoided, could result in death or serious injury.

These winches allow loads to be moved using an appropriate steel or synthetic cable. They have been designed to pull up to a determined rated load and with a static system safety factor of 3.

- The rated load indicated on the winch corresponds to the maximum operating load; this must not be exceeded under any circumstances.

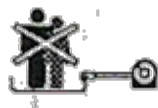

UNDER NO CIRCUMSTANCES MAY THIS WINCH BE USED FOR HOISTING OR TO LIFE OR MOVE PEOPLE.

- Do not start pulling the load until it has been correctly secured and all personnel have left the danger area.
- Before each use, the operator must verify that the winch, its cable, its hook, its markings and its mounting are all in good condition.
- The operator must ensure that the load is attached in such a way that the winch, cable and load do not pose a danger to themselves or others.

The use of winches requires strict compliance with the relevant health and safety practices in the country in which the winch is used.

- HUCHEZ does not accept any responsibility for consequences resulting from the use or installation of devices not covered in this manual, nor does HUCHEZ accept any responsibility for the consequences of disassembly, modification or replacement of original parts or components with third-party parts or components without HUCHEZ's written consent.

This device is subject to European regulations and in particular to Machinery Directive 2006/42/EC and European Standard EN 14492/1.

ANY APPLICABLE REQUIREMENTS AND REGULATIONS IN YOUR COUNTRY MUST ALSO BE COMPLIED WITH.

03 WARRANTY

These electric winches are covered by a 1-year warranty, starting from the date of shipment (from the factory).

This warranty does not cover any wear or damage resulting from a lack of regular maintenance. It also does not cover damage due to a lack of supervision, incorrect operation or improper use of the device, in particular as a result of overloading, pulling diagonally, incorrect supply voltages or faulty connections.

The warranty shall not apply in cases of disassembly, modification or the changing of mechanical or electrical parts without our agreement or by an unauthorised party. The warranty shall only apply to original manufacturer parts. For the duration of the warranty, the seller is obliged to replace or repair any parts recognised as faulty following examination by their approved and qualified service.

This warranty excludes any other provision or compensation.

All repairs under warranty shall be undertaken by the seller or by an agent authorised by the manufacturer. Any parts replaced shall become the property of the seller and must be returned to them.

For particular parts which are not manufactured by the seller and which bear the brand name of specialist manufacturers, the warranty (which may vary depending on the manufacturer), shall be the same as that granted by that manufacturer.

04 RECEIPT OF EQUIPMENT

- Carry out a visual inspection of the packaging to verify that it is in good condition.
- In the case of a fault or problem, write down your concerns on the delivery slip.
- Check that the winch corresponds to the one you ordered.

05 USAGE RESTRICTIONS

 **WARNINGS**

- Do not exceed the rated load capacity indicated in this manual.
- Intermittent use only. Allow the winch to cool between each use.
- Do not use the winch to lift a load (vertically).
- NEVER use the winch to lift or move people in any way.
- NEVER cut, weld or modify any part of the winch or the cable.
- A minimum of five turns of steel cable around the drum are required to pull and hold the rated load. For synthetic cable, ensure a minimum of 10 turns.
- When the winch is in use, please ensure that all people present (including yourself) are a safe distance away from the cable.
- The cable (whether steel or synthetic) may break before the motor stalls. For heavy loads (at or near rated load capacity), use a pulley block to reduce the load on the cable.
- Never step on a cable and never approach a loaded cable.
- Do not move the towing vehicle in order to pull the load with the winch cable. This could cause the cable to break.
- Please ensure that the remote control and battery cables are disconnected when not in use.
- Please avoid jolting the cable by using the controls intermittently to remove slack in the cable. Jolts can far exceed the load capacity of the cable and the drum.
- Do not exceed the maximum rated pulling capacity indicated in this manual.
- When winding the cable, please ensure that it is wound in the correct direction and that it winds around the drum from the bottom and not from the top. To ensure that the cable is wound correctly, you should apply light tension to the cable while pressing the button on the remote control to pull the cable. Move towards the winch to avoid the cable slipping between your hands. Do not move your hands within 30 cm of the winch when winding. Turn off the winch and repeat this process until there are only a few cm of cable left. Disconnect the remote control and finish winding the cable by disengaging the clutch and turning the drum by hand. Keep your hands away from the roller fairlead and the drum when the winch is powered.
- Failure to pay attention to these warnings may result in personal injury and/or damaged property.
- Use gloves to protect your hands when handling the cable. Never allow the cable to slip between your hands.
- Never attach the cable to itself. When the vehicle is on a slope, apply chocks to the wheels. When pulling a load, the winch should be run for the shortest time possible. If the motor becomes too hot to touch, stop winching immediately and allow the motor to cool for a few minutes. Do not run the winch for more than a minute if you are at or near the rated load.

- **Never attach the cable to itself. When the vehicle is on a slope, apply chocks to the wheels. When pulling a load, the winch should be run for the shortest time possible. If the motor becomes too hot to touch, stop winching immediately and allow the motor to cool for a few minutes. Do not run the winch for more than a minute if you are at or near the rated load.**

 **CAUTION**

- **If the motor stalls, do not continue to apply power to the winch. Electric winches are designed and manufactured for intermittent use. They should not be used for continuous usage applications.**
- **Never disengage the clutch while the winch is loaded.**
- **Use the safety strap when handling the hook to wind or unwind the cable.**

06 EQUIPMENT INFORMATION

6.1. General information

This winch is a powerful machine which must be handled with extreme caution with attention paid to all cautions and warnings indicated in this manual. It is important that you understand its specifications and the basics of how it works so that you can use it safely and with complete confidence whenever you need to.

Below, you will find a list of the winch's components and their functions. We recommend that you practice using the winch before finding yourself in a situation where you need to use it.

1. This **winch** is designed for maximum pull strength with a single layer of cable wound around the winch drum (the first layer).
2. The **motor** is fed by a 12-volt battery which powers the gear mechanism that spins the drum and winds the cable. Before use, ensure the winch is connected to the correct supply voltage.
3. The winch **drum** is the cylinder around which the cable is wound. It can unwind or rewind the cable, depending on which button is pressed on the remote control.
4. The winch may be equipped with a **cable** (galvanised steel aircraft cable or synthetic cable, depending on the model), which is specifically designed for a rated pulling load. The cable is wound around the drum from the bottom through the roller fairlead and has a loop at the end to allow the hook to be attached.
5. When the winch is used at an angle, the **roller fairlead** guides the cable onto the drum. This minimises damage to the cable caused by abrasion on the winch support or the vehicle bumper.
6. The **gearbox** converts the power of the motor into an extreme pulling force.

7. A braking action is automatically applied to the drum when the motor is stopped and the cable is loaded. The braking action is complemented by a **separate mechanical brake**.
8. This winch has been designed to be used for multiple winching operations. It can be operated via a wired or wireless remote control.
9. **The clutch** allows the operator to manually disengage ("DISENGAGE") the drum from the gearbox. "ENGAGE" locks the drum to the gearbox.
10. **Solenoid:** Power from the vehicle battery feeds the winch motor via a sealed switch.
11. The power switch cables have a double switch to turn the winch on or off. The **remote control** allows you to keep a safe distance from the cable when it is loaded.
12. The **wireless remote control** (optional, contact us): allows you to control the winch from a distance of up to approx. 15 metres.
13. The winch is supplied with a **mounting plate** which can be mounted on most flat surfaces such as trailers, bumper steps, truck beds, etc. The mounting plate also has holes for attaching the roller fairlead.
14. The winch can also be supplied with a **pulley block** (optional, contact us) to double the winch's pulling power or change the pulling direction without damaging the cable. We recommend that you use a double line and a pulley block when pulling more than 70% of the rated pulling load.

6.2. Technical specifications

Specification	EP3500U	EP4500U
Rated Force	1,588 kg	2,041 kg
Motor: in series	12 V	12 V
	Input: 2.4 kW Output: 1.0 kW	Input: 2.5 kW Output: 1.1 kW
Gear ratio	170: 1	166: 1
Cable (Dia. × L)	Ø 5.4 mm × 12.8 m	Ø 6 mm × 14.5 m
Drum size (Dia. × L)	Ø 37 mm × 80 mm	Ø 50.4 mm × 125 mm
Mounting dimensions / Mounting bolts	124 mm x 76 mm / 2 – M8	168 mm x 76.2 mm / 4 – M8
Net weight (kg)	10.0	15.5

Table of load capacity per layer:

EP3500U		
1 st layer pulling load (kg)	Speed (m/min)	Current (A)
0	3.2	20
454	2.7	75
907	2.3	130
1,588	1.4	200

EP4500U		
1 st layer pulling load (kg)	Speed (m/min)	Current (A)
0	3.9	28
454	3.0	80
907	2.6	120
1,361	2.1	160
2,041	1.4	220

Table of cable capacity per layer:

Ref.	EP3500U		EP4500U	
Layer	Rated Force (kg)	Cable drum capacity (m)	Rated Force (kg)	Cable drum capacity (m)
1	1,588	1.8	2,041	3.7
2	1,265	4.1	1,742	8.0
3	1,052	6.7	1,501	12.8
4	900	9.5	1,319	14.5
5	786	12.8		

6.3. Dimensions

EP3500U

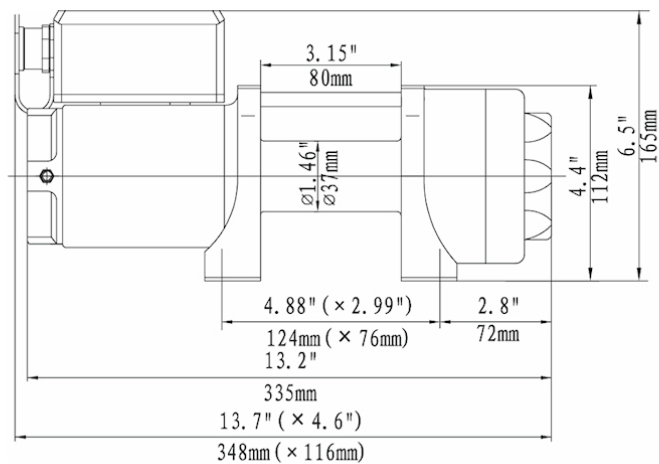

EP4500U

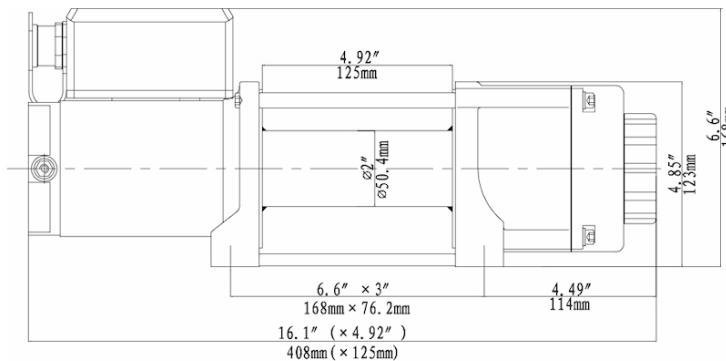

07

MOUNTING - INSTALLATION

Accessories you will need which are not included with the winch:

- **Gloves for handling the cable and hook safety strap.**
 - **Anchoring sling/chain.**
 - **Blanket to throw over the cable to absorb the energy if the cable breaks.**
1. The winch is designed with a standard bolt pattern for this class of winch. Many winch mounting kits use this bolt pattern for common vehicles and mounting plates. If you wish to use a mounting plate, ensure that it is mounted on a flat surface so that the motor, drum and gearbox housing are correctly aligned. Correct alignment of the winch will ensure uniform distribution of a rated load.
 2. Begin by assembling the roller fairlead and the mounting plate using 2 screws. Ensure that the screws are inserted through the mounting plate from the inside and through the roller fairlead. This will ensure that there is enough space for the winch to be placed on the plate.
 3. Assemble the winch on the mounting plate by pulling and turning the clutch switch to the "DISENGAGE" position. Pull a few centimetres of cable from the drum and pass the cable loop through the opening at the front of the mounting plate and through the roller fairlead. You may now attach the winch to the mounting plate using the remaining screws.
 4. Connect the battery and the motor cables as shown in the diagram below. Bear in mind that each type of winch is different.

⚠ CAUTION

Batteries contain inflammable and explosive gases. Always wear protective goggles during installation and remove all jewellery beforehand. Do not lean over the battery while making the different connections.

5. Attach the clevis hook to the cable: remove the pin from the hook, connect the hook to the cable and replace the pin.
6. Always use the safety strap when winding or unwinding the cable. Using the nylon strap will help you to keep your hands and fingers away from the drum when it is rotating.
7. Check that the drum rotates correctly. Pull and turn the clutch switch to the "DISENGAGE" position. Manually pull out some of the cable and then, turn the clutch switch to the "ENGAGE" position to lock the gearbox to the drum. Press the "OUT" button on the remote control. If the drum turns and unwinds the cable, your connections are correct. If the drum turns and winds up the cable, swap the motor connections. Repeat and check the drum rotation.

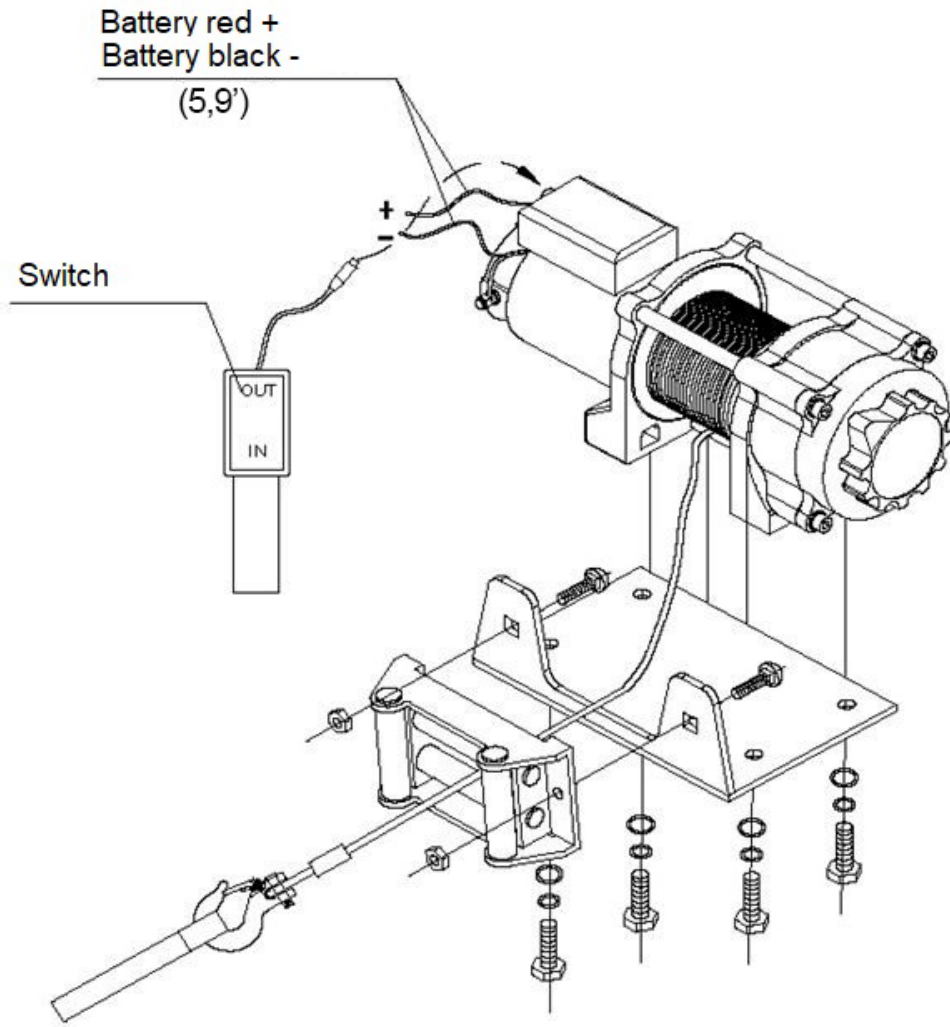

08

COMMISSIONING - USAGE

Do not use this equipment without having first fully read and understood the user manual. Failure to pay attention to these instructions whilst using this equipment poses a risk to your safety. Before using the equipment, please, observe and apply the following safety instructions:

- The rated load of the winch indicates the force applied to the first layer on the drum. Overloading can damage the winch, motor or cable. For loads greater than 70% of the rated load, we recommend using a double-line with pulley block. This will reduce:
 - the number of layers of cable on the drum,
 - the load on the cable by 50%. When you double the line and attach the return line to the vehicle, attach it to the chassis or another load-bearing part.
- The vehicle engine must be kept running while the winch is running in order to minimise the drain on the battery and maximise the power and speed of the winch. If the winch is operated for a considerable time with the engine off, the battery will drain and you may not be able to restart the engine.
- Get to know your winch before you actually need to use it. We recommend that you carry out some trial runs to practice attaching the cable, familiarise yourself with the sounds your winch makes under different loads, observe the way the cable is wound around the drum, etc.
- Inspect the cable and equipment before each use. A frayed or damaged cable must be replaced immediately. Only use a cable that meets the specifications recommended by the manufacturer.
- Inspect the winch's installation and bolts to ensure that all bolts are secure before each use.
- Never attach the cable to itself or it may become damaged. Always use a pulley block, sling or an appropriate-strength chain, as shown in the illustrations.
- Store the remote control inside your vehicle in a place where it will not get damaged.
- Any winch that looks to be damaged in any way, is found to be worn, or is not functioning correctly should no longer be used.
- When towing a vehicle, only pull on parts specified by the vehicle manufacturer.
- Only accessories and/or adapters supplied by the manufacturer should be used.
- Before using your winch, briefly test it in both directions. Even if the drum is only at an angle of a few degrees, ensure that the winch is well balanced, especially if you have used the clutch. The test will engage the gearbox with the drum once again if necessary.

8.1. Winch cable techniques

Auto-recovery

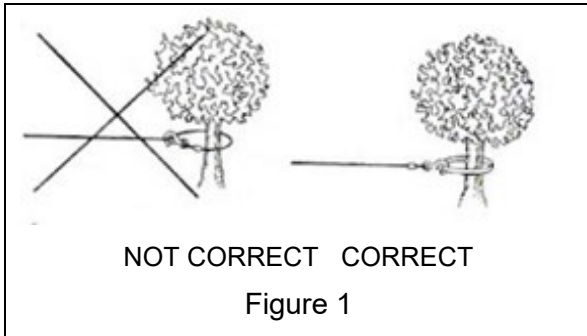

Identify a suitable anchor point. When choosing an anchor point, choose a strong, firm point such as a tree trunk or rock. Always use a sling as an anchor.

⚠ CAUTION

Do not attach the hook to the cable as shown in Fig. 1, it could become damaged.

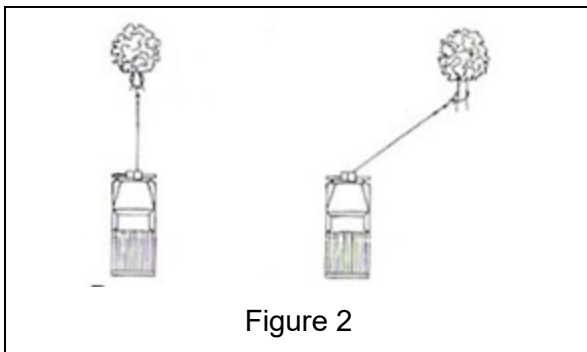

⚠ CAUTION

Do not winch at an acute angle. Doing so will cause the cable to wind on one side of the drum, which could damage the cable and the winch, as shown in Fig. 2

Short angle pulls can be used to straighten the vehicle. Long pulls should be done with the cable at a 90° angle to the winch/vehicle.

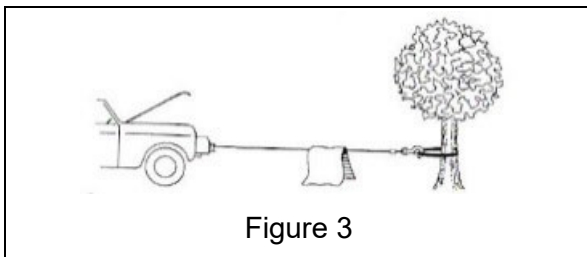

When pulling a heavy load, throw a blanket or jacket over the cable about 1.50 m from the hook. This way, if the cable breaks, the whiplash will be absorbed. For extra protection, open the bonnet of your vehicle as shown in Fig. 3.

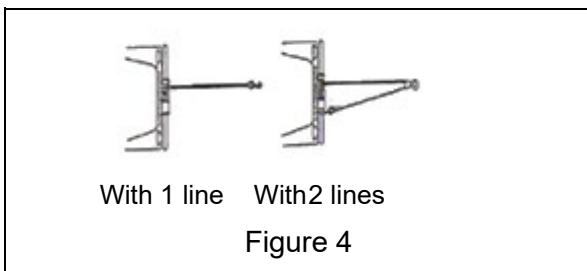

For pulling loads greater than 70% of the rated load, we recommend using a pulley block to double the line. Fig. 4.

This will reduce the load on the winch and the tension on the cable by up to 50%, depending on the angle.

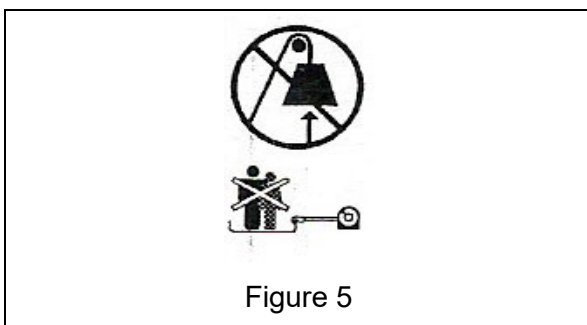

⚠ WARNING

Never use the winch for hoisting or lifting or moving people. Fig. 5.

8.2. Operating the winch

➤ Preparation before winching

1. Take some time to assess the situation and prepare your winching operation appropriately.
2. Wear gloves to protect your hands.
3. Disengage the clutch by turning the switch to the DISENGAGE position. This will allow the cable to unwind freely and will save energy.
4. Attach the safety strap to the hook.
5. Pull the cable to the desired anchor point using the safety strap.
6. Attach the hook to the anchor point using a sling, chain or a pulley block. Do not hook the cable onto itself.
7. Engage the gearbox by turning the switch to the ENGAGE position.
8. Connect the remote control to the winch.
9. Start the vehicle engine to ensure that the battery is charging. The vehicle engine must be running to provide maximum power to the winch. The vehicle should be in neutral with the handbrake applied. Chock the wheels to prevent it from moving.
10. Gradually put the cable under tension by gently guiding it. Once the cable is under tension, keep a safe distance. Never step on the cable.
11. Disengage the clutch to allow the drum to turn freely and to save energy.
12. Inspect the cable. Make sure there are the minimum number of turns required around the drum.
13. Place a blanket or jacket over the cable about 1.50 m from the hook. Open the vehicle bonnet for extra protection.
14. Make sure the area is clear. Ensure that all other people keep a safe distance away and that no one is directly in front of or behind either the vehicle or the anchor point.

➤ Winching operation

15. Start winching. Ensure the cable wraps evenly and tightly around the drum. The towing vehicle may be driven slowly to assist the winching process. Avoid jolting the cable. Keep the cable under tension.
16. If towing a vehicle, the vehicle in question must be in neutral with handbrake released. Only release the brake pedal when maximum tension is reached. Avoid jolting the load as this could damage the winch, the cable and the vehicle.
17. The winch is designed for intermittent use. When pulling a full load with a single line, do not winch for more than one minute at a time. Allow the motor to cool for a few minutes, then resume winching.
18. Winching is complete once the vehicle in question is on stable ground and can be driven under its own power.
19. Secure the vehicle. Be sure to park the vehicle and apply the brakes.
20. Release the tension on the cable. The winch is not designed to hold the vehicle for a long time.
21. Detach the cable from the anchor point.
22. Rewind the cable. Ensure that all of the cable already wrapped around the drum has been wound correctly. If this is not the case, pull the cable out and wind it again with the cable under tension.
23. Keep your hands away from the drum and the roller fairlead whilst winding the cable around the drum.

24. Secure the hook and the safety strap.
25. Unplug the remote control and store it in a suitable, dry place.
26. Clean and inspect the connections and mounting equipment for the next winching.

09 MAINTENANCE

9.1. Winch

1. Periodically check the tightness of the mounting bolts and electrical connections. Remove any dirt or corrosion and ensure the winch is always kept clean.
2. Do not attempt to disassemble the gearbox.
3. The gearbox has been lubricated with high-temperature lithium grease and is factory-sealed. No internal lubrication is required.

9.2. Cable

If the cable is worn or begins to show signs that it might break, it must be replaced before using the winch.

1. Move the switch to the "DISENGAGE" position.
2. Pull out the full length of the cable. Take note of the manner in which the existing cable is attached to the drum.
3. Remove the old cable and attach a new cable to the drum. Insert the end of the new cable and tighten the M6x8 screw (Ref. P0450011).
4. Ensure that the new cable is wound around the drum in the same direction as the old one. The cable must leave the drum from underneath the drum.
5. Move the switch to the "ENGAGE" position.
6. Wind the cable around the drum. The first five turns of steel cable (first 10 for synthetic cable) should be done carefully so that the cable is wound correctly. Next, the cable should be wound onto the drum with a load of at least 10% of the rated pulling force.

WARNING

Any replacement cable must meet the same specifications as those recommended by the manufacturer.

10 DECOMMISSIONING

If the equipment is in a condition which is likely to be hazardous, the user is obliged to ensure that the equipment is disposed of by decommissioning it and, where necessary, dismantling it.

11

SPARE PARTS

If you notice during maintenance tasks that certain parts of your winch need replacing, only original parts from the manufacturer should be used.

When ordering spare parts, please provide the following information:

- **The type and force rating of the winch.**
- **The series number.**
- **The number or description of the desired parts (see exploded-view diagrams).**

12 TROUBLESHOOTING

SYMPTOM	POSSIBLE CAUSE	SUGGESTED ACTION
The motor does not start	<ul style="list-style-type: none"> - The remote control is not connected correctly - The battery connections are not tight enough - Faulty remote control - Faulty motor - Water has entered the motor 	<ul style="list-style-type: none"> - Reconnect the remote control correctly. - Tighten the nuts on all cable connections. - Replace the remote control. - Check that there is power by pressing the button on the remote control. If there is power, replace the motor. - Let the motor drain and dry. Operate the winch intermittently with no load until completely dry.
The motor runs, but the drum does not turn	<ul style="list-style-type: none"> - Clutch not engaged 	<ul style="list-style-type: none"> - Place the clutch in the "ENGAGE" position. If the problem persists, the winch should be checked and repaired by a qualified technician.
The motor runs slowly or does not run at normal power	<ul style="list-style-type: none"> - Low current or voltage 	<ul style="list-style-type: none"> - Weak battery recharge. Try operating the winch with the vehicle engine running. - The battery connections are not tight enough or are corroded. Clean, tighten or replace them.
Motor overheating	<ul style="list-style-type: none"> - The winch is being used for too long 	<ul style="list-style-type: none"> - Allow the winch to cool down regularly.
The motor only works in one direction	<ul style="list-style-type: none"> - Faulty remote control 	<ul style="list-style-type: none"> - The battery or motor connections are not tight enough or are corroded. Clean and tighten them. - Repair or replace the remote control.

13 EC DECLARATION OF CONFORMITY

CE



UE DECLARATION OF CONFORMITY

F03.31.1 - UK ELECTRIC WINCHES FOR VEHICLES

We hereby declare, under our sole responsibility, that the design and manufacture of the machinery referred to below comply with the following essential requirements of harmonization laws of the European Union:

- Directive 2006/42/EC on Machinery
- Directive CEM 2014/30/UE

The machinery's technical file has been put together by the signatory of this declaration. This declaration shall become null and void in the event it is changed or if any item is added without our prior consent. Moreover, this declaration shall become null and void if the machinery is not used in accordance with its instructions for use and if it is not inspected regularly.

Type of device: Electric winch for vehicle

Model:

Force:

Serial n°:

Function : Hauling only

Harmonised standard(s) used, notably: EN ISO 12100:2010, EN 14492-1:2006+A1:2009+AC:2010, EN 60204-32:2008

Quality assurance : ISO 9001 (certificate registration n°: FQA 9911492)

Equipment delivered : with cable : Synthetic Steel with hook

without cable without hook

Important: these items must comply strictly with the specifications indicated on the manufacturer's plate affixed to the winch and the instructions for use, and they must be supplied by professionals specialized in their use.

For hauling only.

and with instructions for use.
Issued in Ferrières en

Antoine HUCHEZ,
President

hucnez.com

HUCHEZ S.A.S.
1, rue Michel Hamard
50420 Ferrières (France)

Tel : +33 (0)3 44 51 11 33
contact@hucnez.fr

S.A.S. au capital de 500.000€
SIRET: 526 007 482 20024
SC: 326998403.65 - APE: 2822 Z
N°A: 18 89 520 402 462



14 EXPLODED-VIEW DRAWINGS

EP3500

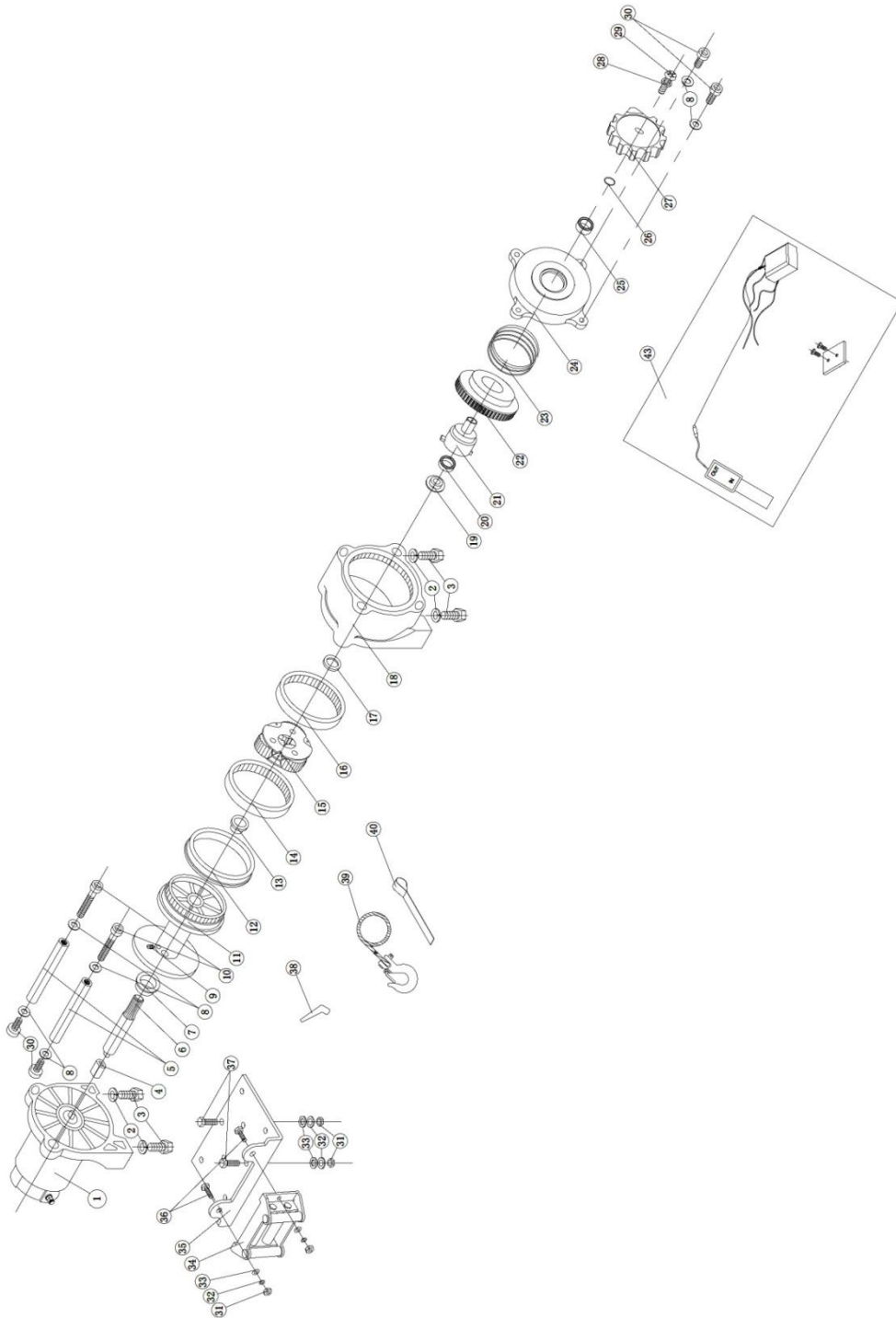

No.	Part No.	Qty	Description
1	P0350100-U	1	Motor assembly
2	P0250001	4	Lock washer Φ 8
3	P0250002	4	Assembly screw, M8x15
4	P0250003	1	Transition shaft
5	P0250004	2	Coupling rod
6	P0250005	1	Hexagonal shaft
7	P0250006	1	Bushing, pre-drum
8	P0250007	6	Spring washer Φ 6
9	P0250008	1	Screw, M6x8
10	P0250009	2	Assembly screw M6x70
11	P0250010	1	Drum
12	P0250011	1	Rear bearing
13	P0250012	1	Front thrust washer
14	P0250013	1	Ring gear
15	P0250200	1	Gear set
16	P0250014	1	Gearbox collar
17	P0250015	1	Trust washer
18	P0250016	1	Gearbox housing / Rear bearing
19	P0250017	1	Bearing support
20	P0250018	1	Roller bearing
21	P0250019	1	Clutch shaft
22	P0250020	1	Clutch release pin
23	P0250021	1	Spring
24	P0250022	1	Gearbox cover
25	P0250023	1	Roller bearing
26	P0250024	1	Rubber seal
27	P0250025	1	Clutch handle
28	P0250026	1	Lock washer Φ 5
29	P0250027	1	Assembly screw M5x12
30	P0250028	4	Assembly screw M6x25
31	P0250029	4	Hexagonal nut, M8
32	P0250030	4	Lock washer Φ 8
33	P0250031	4	Washer Φ 8
34	P0250300	1	Roller fairlead
35	P0250032	1	Mounting plate
36	P0250033	2	Assembly screw M8x20
37	P0250034	2	Assembly screw M8x35
38	P0250035	1	Strap
39	P0350400	1	Cable
40	P0250036	2	Terminal protectors
43	P0350700	1	Control enclosure

EP4500

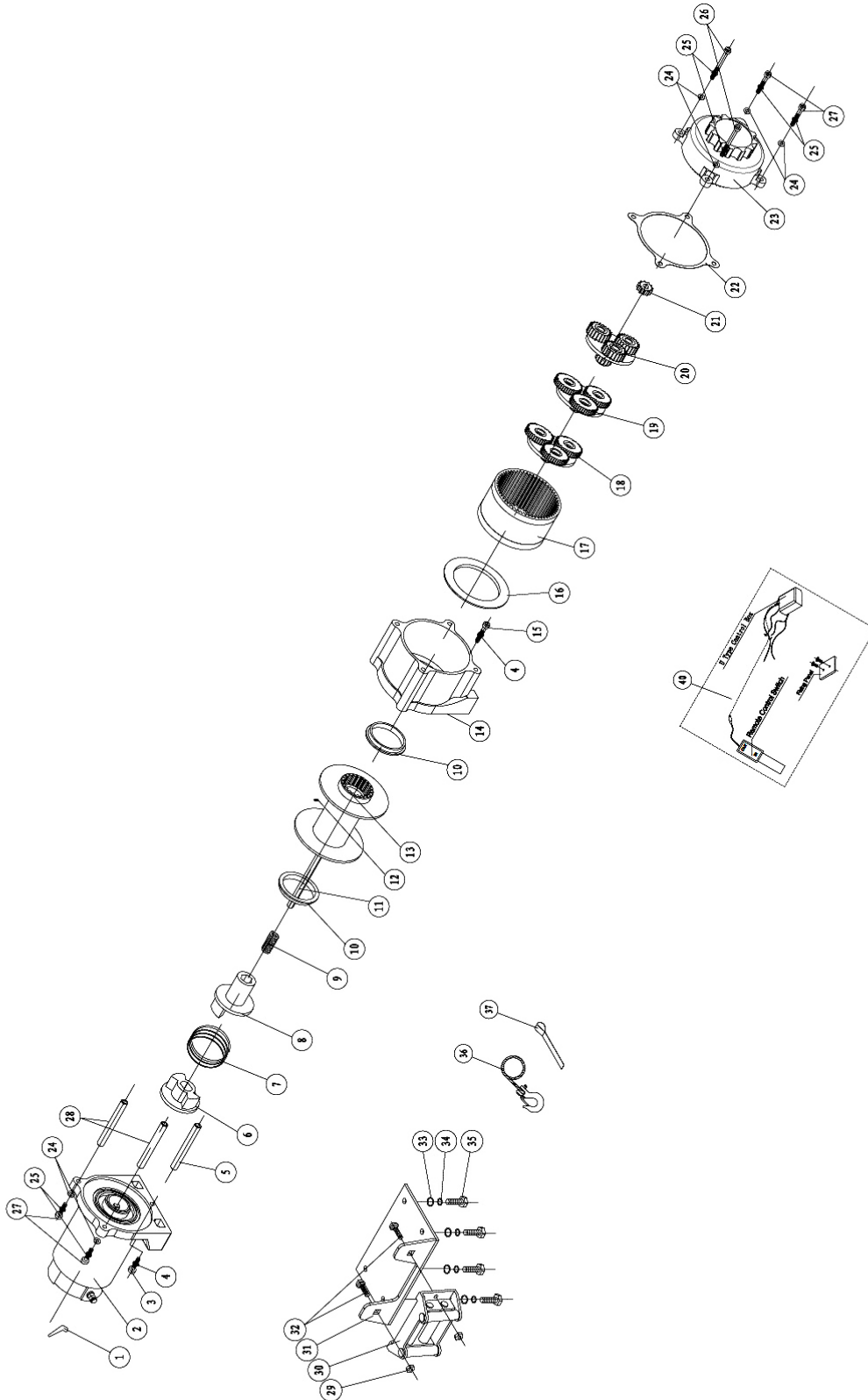

No.	Part No.	Qty	Description
1	P0450001	2	Terminal protectors
2	P0450100-U	1	Motor assembly
3	P0450002	1	Screw M4x15
4	P0450003	4	Lock washer Φ 4
5	P0450004	1	Tie rod
6	P0450005	1	Coupler I
7	P0450006	1	Spring
8	P0450007	1	Coupler II
9	P0450008	1	Spring
10	P0450009	2	Bearing
11	P0450010	1	Hexagonal shaft
12	P0450011	1	Screw, M6x8
13	P0450200	1	Drum
14	P0450012	1	End bearing
15	P0450013	1	Screw M4x25
16	P0450014	1	Seal
17	P0450015	1	Gearbox collar
18	P0450300	1	Gear set (Output)
19	P0450400	1	Gear set (Intermediate)
20	P0450500	1	Gear set (Input)
21	P0450016	1	Gear
22	P0450017	1	Seal
23	P0450600	1	Clutch handle
24	P0450018	6	Thick washer Φ 6
25	P0450019	6	Lock washer Φ 6
26	P0450020	2	Screw, M6x100
27	P0450021	4	Screw, M6x20
28	P0450022	2	Coupling rod
29	P0450023	2	Hexagonal nut, M10
30	P0450700	1	Roller fairlead
31	P0450024	1	Mounting plate
32	P0450025	2	Screw, M10x20
33	P0450026	4	Washer Φ 8
34	P0450027	4	Lock washer Φ 8
35	P0450028	4	Screw, M8x25
36	P0450800	1	Cable
37	P0450029	1	Strap
40	P0451100	1	Control enclosure

